

Worcester Greenskies FK240 Solar Panels – harnessing natural energy for hot water comfort

Greenskies FK240 Solar Panels

Features

- Efficient collector with 92% absorption rate.
- Robust panel design.
- Environmentally friendly.
- Quick Fitting.
- Easy to fit.
- Simple to use controller.
- Selective coating on absorber.
- Strong solar glass cover.

Benefits

- Increases performance of panel.
- Minimises risk of damage and prolongs service life.
- All materials recyclable, environmentally conscious manufacture.
- Labour and money saving.
- Reduces complexity of installation.
- Allows quick setting of functions.
- Increases collector performance even on cloudy days.
- Protects collector from damage.

Global responsibility for nature and the environment

As part of the Bosch group, Worcester Bosch is committed to environmental protection. Product development is prioritised in the interests of the safety of people, the economical use of resources and environmental sustainability.



With this in mind Worcester Bosch is proud to offer a solar panel package for hot water heating which allows the consumer to take advantage of renewable and sustainable energy.

Worcester Greenskies FK240 Solar Panels harness the power in both direct and diffused sunlight and convert the energy to heat for the production of hot water for the home.

The solar panels have been designed as a complement to existing heating systems which use a store of hot water in a cylinder. The existing cylinder is exchanged for a cylinder with two heat exchanger coils; one from the boiler in the property and a second from the solar panels.

The Worcester Greenskies FK240 Solar Panels are an ideal partner to the new range of condensing Greenstar regular and system boilers, with different models available in both oil and gas, which require a separate cylinder for the storage of hot water. When used together a Greenstar boiler with solar system provides a highly efficient system to give heating and hot water comfort.

A typical well sized solar system should provide around 50% of the domestic hot water requirements of a home, representing a very worthwhile saving on hot water heating costs. The remaining hot water requirement is provided by the boiler.

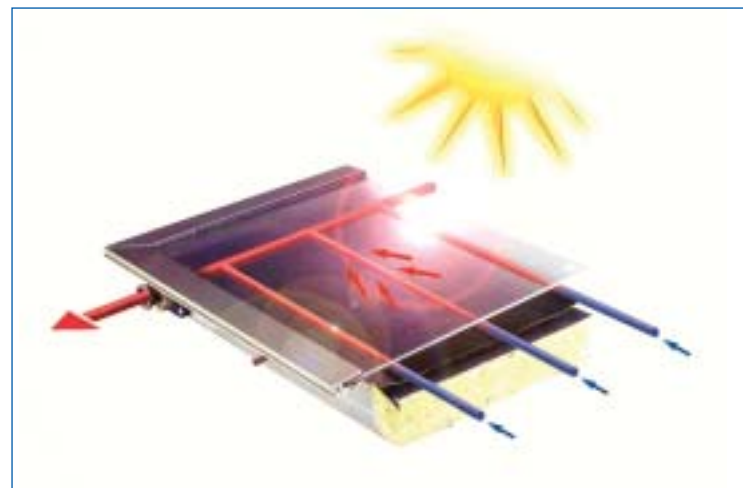

Principle of operation



Greenskies FK240 Solar Panels at a glance

		Greenskies FK240 Solar Panel
Outer Surface		2.4m ²
Absorber Surface		2.1m ²
Selectivity	Absorption	92%
	Emission	12%
Min. Efficiency		525 kWh/m ² a
Weight		43Kg
Max. Operating Pressure		3 bar

Worcester Greenskies FK240 Solar Panels

Operation

Worcester Greenskies FK240 Solar Panels form part of a system which remains separate from the boiler heating system.

The panels are mounted on a surface which is selected for its exposure to sunlight and usually connected, via pipe work, to the lower coil of a twin-coil solar cylinder. The energy in the sun's rays is absorbed by the panel and the heat is transferred into the pipe work in the absorber plates. The pipe work is filled with a ready-mixed liquid, containing glycol and water, which is circulated by a pump to the coil in the hot water cylinder. The heat is deposited in the storage cylinder and the glycol returns to the panel to absorb more free solar energy. The system is equipped with a simple unit to control the flow of energy from the panels to the storage cylinder.

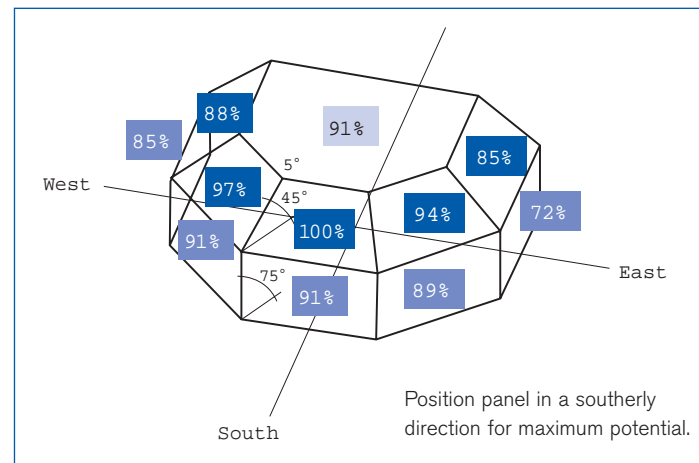

Panel performance

Each Worcester Greenskies FK240 collector has a net surface area of 2.1sq.m. with a minimum efficiency of 525kWh/m²a. The panels are covered with solar glass which helps the selective coating on the copper collector absorb 92% of the available energy. The panel contains 60mm of mineral wool which contributes to the low 12% emission rating.

A common question (see the FAQ section for more) about solar in the UK focuses on whether there is enough sunshine available to make solar worthwhile. The usual idea of British weather is of cloudy skies and intermittent sunshine. Worcester's solar panels have been developed with this typical weather in mind and make the most of both direct and diffused sunlight to give a useful annual contribution wherever you are in the UK.

Solar Radiation in the British Isles

Contrary to popular belief the amount of solar radiation received by the UK is enough for solar water heating to be a viable supplement to existing domestic water heating. Perhaps surprisingly the UK receives 65% of the amount of solar radiation that is received by the south of Spain. The radiation in the UK is made up of direct radiation on sunny days, which accounts for around 40%, and diffused radiation on cloudy days, accounting for 60% of the total.

Summer will provide the largest amount of radiation over the year but a useful contribution will be provided by other seasons.

As an indication, a well sized typical installation will provide the following proportion of the household domestic hot water requirement:

Season	% of requirement fulfilled by solar
Summer	80-90%
Spring & Autumn	40-50%
Winter	20-30%

This translates to roughly half of the typical annual domestic hot water requirement.



Controls

The Worcester solar package includes a simple controller (TDS10) which allows the user to select the temperature required at the hot water cylinder. The controller then automatically decides when to run the pump to bring the energy from the panels to the cylinder.

The control uses a simple temperature difference to define when the pump runs. The temperature in the panel must be 8 degrees higher than the store for the pump to start running. This will continue until the panel temperature gets to 4 degrees above the store and then the pump will stop.

This ensures that the pump is only running when the benefit from the solar panels is available.



Technical data

Classification	Greenskies FK240 Solar Panel Package
Panel height	112mm
Panel width	1,135mm
Panel length	2,115mm
Weight (empty)	43kg
Fluid content	1.15 litres
Gross surface area	2.4m ²
Net surface area	2.1m ²
Stagnation temperature	181°C
Max operation pressure	3 bar
Min efficiency	525 kWh/m ² a
Absorption	92%
Emission	12%
Glycol freezing temperature	-38°C
Max collectors in series	9

Application of Worcester Greenskies Solar Panels

Worcester offers a complete package (with the exception of the solar cylinder and ancillaries) for a solar water heating solution as an addition to an existing or replacement boiler. The solar panels can also be used for other water heating requirements such as heating of swimming pools.

The panels can be mounted directly onto sloping roofs with a variety of fixings for different roof coverings or onto a frame for flat roofs.

The solar panels should be installed in a southerly direction at an angle of around 45 degrees. Where this is not possible the installation should move towards a westerly facing direction.

East and North facing directions should be avoided.

Greenskies FK240 Solar Panels – up close

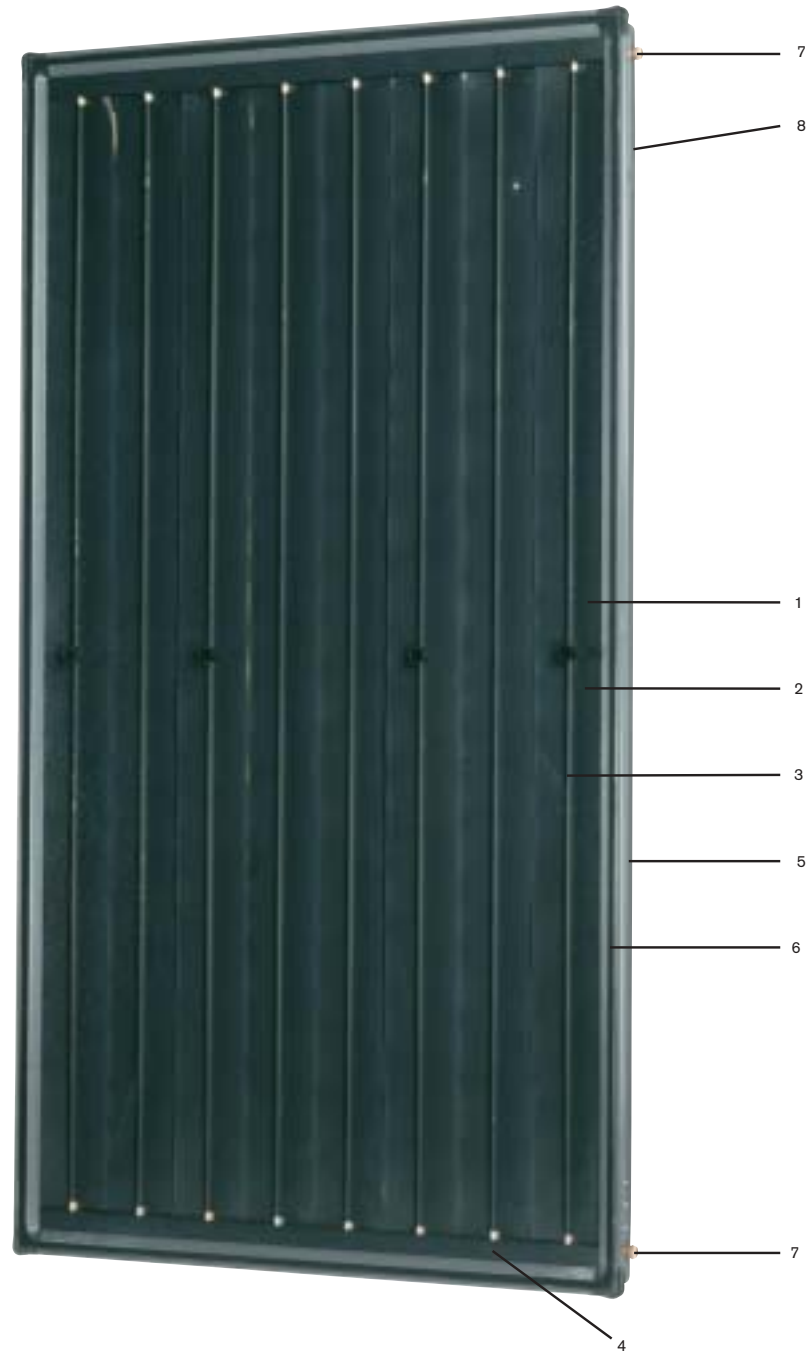

Key to components

1. Highly transparent, hardened solar glass
2. Selective coated copper absorber
3. Heat transfer tubes
4. Main collector pipe
5. Surrounding tray – UV resistant 2-layer plastic
6. Glass fibre frame
7. Pipework connections
8. Temperature-measurement point (Thermostat Pocket)

Greenskies FK240 Solar Panel System layouts

Typical solar system for hot water with twin coil cylinder and conventional boiler

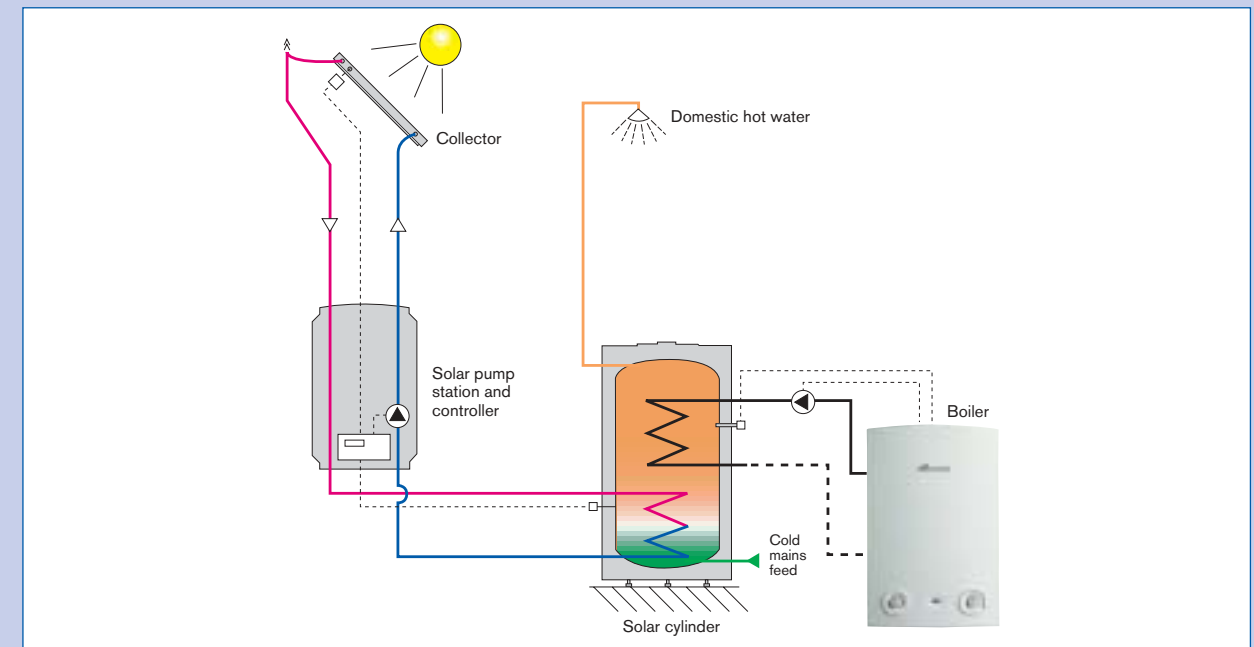

The most common solar system layout uses a twin coil cylinder which is fed by both a boiler (or other heat source) and the solar panels. The solar system and the regular heating system do not come into direct contact with each other and the only shared part is the cylinder.

The solar system has its own pump, expansion vessel, pressure relief valve, air vent and controller.

The Worcester solar package is ideally suited for use with Worcester Bosch oil or gas fired regular or system boilers. These are listed below:

Worcester Bosch Boiler Compatibility

Gas

Greenstar 12i System
Greenstar 24i System
Greenstar 12Ri
Greenstar 15Ri
Greenstar 18Ri
Greenstar 24Ri
Greenstar 30CDi Conventional
Greenstar 40CDi Conventional
15SBi
24SBi
9-14CBi
14-19CBi
19-24CBi

Oil

Greenstar II HE 12/22
Greenstar Danesmoor 18/25
Greenstar Utility 18/25
Greenstar Utility 32/50
Greenstar Utility 50/70
Danesmoor WM 12/19
Danesmoor 12/14 - Kitchen, Utility and System models
Danesmoor 15/19 - Kitchen, Utility and System models
Danesmoor 20/25 - Kitchen, Utility and System models
Danesmoor 26/32 - Kitchen and Utility models
Danesmoor 32/50 - Utility models
Danesmoor 50/70 - Utility models
Danesmoor FS 12/18
Danesmoor FS 18/25

Planning

In general the installation of solar panels, as far as planning permission is concerned, is reasonably straight-forward with most local authorities regarding the panels in a similar vein as to flush fitting roof-light windows, where planning permission may not be

required. However it is prudent to seek the opinion of the local authority on planning matters prior to starting work on the solar installation. Requirements vary from one authority to the next both with planning permission and building control procedures.

Installing Greenskies FK240 Solar Panels

Site preparation/portability

In addition to ensuring that the panels are sited in the correct direction and away from sources of shade, particular attention should be paid to site access and the safe installation of the panels.

When working at height care should be taken to ensure that the required safety equipment is available and correctly used.

Panel dimensions and clearances

Dimension A and B

Dimensions A and B correspond to the area required for the selected number and layout of the collectors.

Dimension C

Dimension C represents at least two tiles to the ridge. A space of the equivalent of two tiles should be allowed for to avoid damage at the roof ridge, particularly if the tiles are laid in mortar.

Dimension D

Dimension D corresponds to the roof height including the gable wall. The adjacent 50 cm clearance to the collector array is required under the roof on the right or left depending on the type of connection.

Dimension E

Dimension E corresponds to at least 30 cm, which is required in the attic for installation of the connection pipes.

Dimension F

Dimension F corresponds to at least 40 cm, which is required in the attic for installation of the connection pipes.

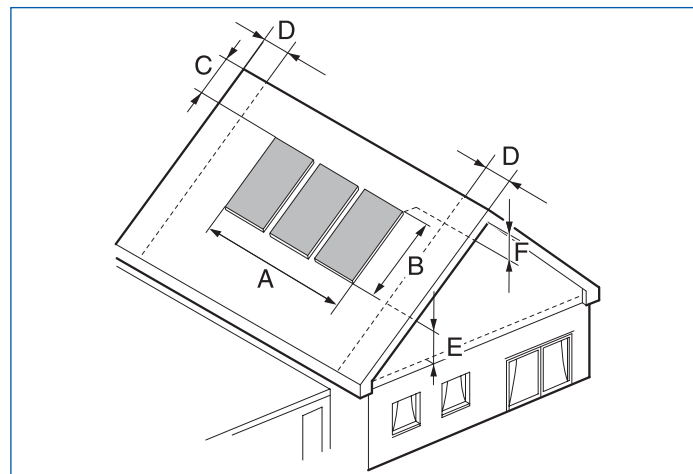

Space required for collector array

No. of collectors	Dimension A	Dimension B
2	2.34m	2.20m
3	3.51m	2.20m
4	4.68m	2.20m
5	5.85m	2.20m
6	7.02m	2.20m
7	8.19m	2.20m
8	9.36m	2.20m
9	10.53m	2.20m

Space requirement

Panel support assembly

Each panel is secured onto a pair of rails which can be assembled on the ground and then raised to the roof. The rails can then be mounted on the roof hooks, which are available to suit various roof and tile types.

In addition, the Worcester Greenskies FK240 Solar Panels are available with a support kit for installation on flat surfaces, offering greater possibilities for installation.

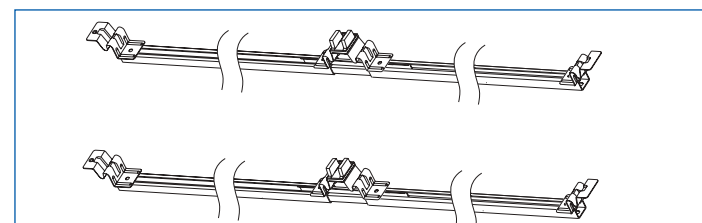

Preassembled profile rails for two adjacent collectors

Connecting profile rails

Individual rails are joined with a rail connector into which the rails slide for an easy connection.

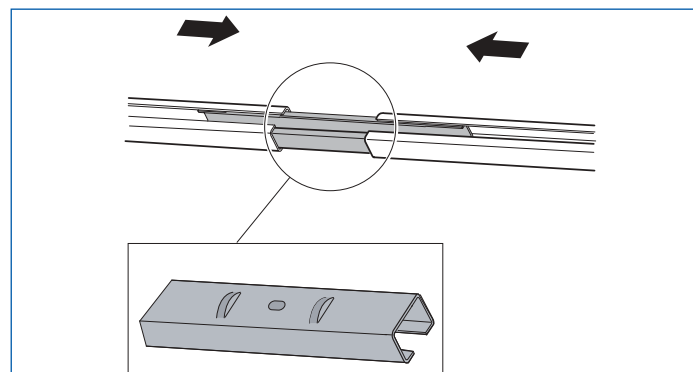

Rail connection

Pipework Connections

Worcester Greenskies FK240 Solar Panels are equipped with simple push-fit connections which speed installation and, with bespoke flexible hoses, aid the routing of pipework into the roofspace. Once inside the property the system should be run in copper pipe.

Flexible hose connections are secured with a simple quick release clip which closes automatically and allows the time required for pipework on the roof to be reduced.

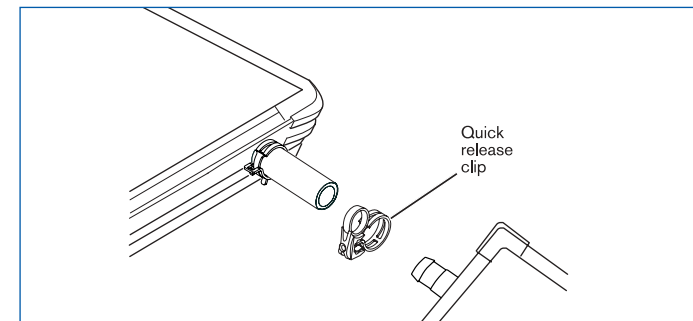

Subsequent collectors in series also use this connection method to enable arrays to be plumbed-in with ease.

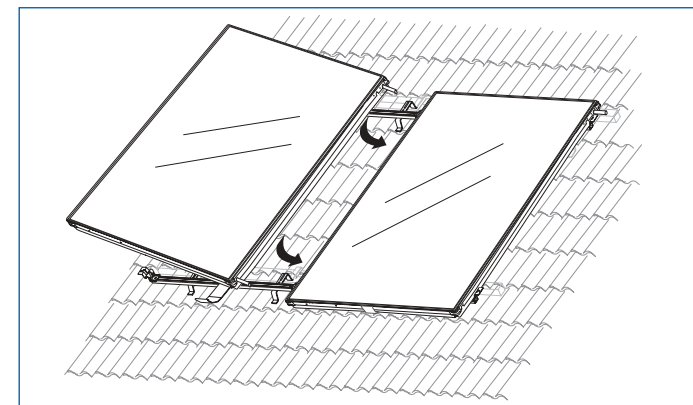

The second panel (of a two panel array) can be added easily with push-fit connections.

Cylinders

For most installations a hot water store of around 75-100 litres per collector is normally well suited. For a two panel installation a cylinder of around 175 litres offers a good combination of hot water storage and space usage.

Suitable hot water storage cylinders are available from:

Albion, Shelah Road, Halesowen, West Midlands B63 3PG
Tel: 0121 585 5151

Range, Tadman Street, Wakefield, West Yorkshire WF1 5QU
Tel: 01924 234514

Installation requirements

The installation of the Worcester solar system must be carried out in accordance with the relevant requirements for safety, current Wiring Regulations, local Building Regulations, Building Standards (Scotland), (Consolidation) Regulations and Bylaws of the local water company and Health and Safety document No. 63S (Electricity at Work Regulations 1989). It should be in accordance with the relevant recommendations of the following British Standards and Regulations:

BS 5918:1989
The Health and Safety at Work Act 1974
The Management of Health and Safety at Work Regulations 1999
The Construction (Health, Safety and Welfare) Regulations 1996
The Construction (Design and Management) Regulations 1994
The Lifting Operations and Lifting Equipment Regulations 1998

The manufacturer's notes must not be taken in any way as overriding statutory regulations.

Electricity supply

A 3 amp fused three pin plug and unswitched shuttered socket outlet (both complying with BS 1363) or preferably a double pole isolator with a contact separation of 3mm in all poles supplying the controller should be used. The controller must be earthed.

Glycol heat transfer liquid

Worcester Greenskies FK240 Solar Panels and system components should be used only with the recommended heat transfer liquid – Tyfocor©L manufactured by Tyforop Chemie GmbH, available at stockists of Worcester Greenskies FK240 Solar Panels.

The heat transfer liquid uses a proven concentration of anti-freeze and water to give protection against freezing and provide optimum performance from the panels and system.

Hot water blending valve

It is recommended a thermostatic blending valve be used in conjunction with the solar cylinder in order to guard against the high hot water temperatures which the system can provide.

Insulation

Exposed pipework should be insulated according to the high temperatures that the panels are able to generate. Insulation rated to 150°C must be used. Suitable insulation is available from Armacell UK Ltd., Mars Street, Oldham, Lancashire OL9 6LY.

Pressure relief valve

The AGS2 Solar pump station in the Worcester Greenskies FK240 solar package is equipped with a 3 bar pressure relief valve which should be connected to pipe work terminating in a suitable container. An empty canister of heat transfer fluid can be used for this purpose.

Warranty

Worcester is proud to offer a guarantee of 5 years on the Greenskies FK240 Solar Panels and a 2 years warranty on other components.

FAQ's

Q. What is sustainable energy?

A. Sustainable energy is best thought of as energy which can be replenished within a human lifetime and which causes no long-term damages to the environment. Solar energy, wind energy, and geothermal energy, amongst others, are all self-sustaining. They all have sources that cannot be depleted. Extended use of these energy sources aids the conservation of other non-renewable energy sources such as fossil fuels.

Q. How does Solar technology work?

A. The idea behind technologies which use solar energy is to harness the freely available rays from the sun in a useful form. The technology used for solar water heating is simple and effective. The basic principle uses an absorber plate which is heated by the sun's rays. This heat is collected in a transfer liquid which is in turn used in a heat exchanger to heat water.

Q. What if there is no sun or it is a cloudy day?

A. Special coatings are available on the absorber plates which allow the collector to absorb energy from diffused as well as direct sunlight. This means the panel can still yield results on days when there are clouds in the sky.

Q. Is there any Government funding available?

A. The Department of Trade and Industry is funding an initiative called Clearskies which entitles home owners and not-for-profit organisations to financial help with a solar system. Householders can apply for a grant of £400 regardless of system size.

Q. Do I have to pay VAT for installing Solar panels?

A. The VAT on solar systems varies depending on who is installing it. DIY solar systems carry 17.5% VAT. A system which is installed by a professional installer carries 5% VAT.

Q. Do I still need a boiler?

A. Solar heating on a normal domestic scale in the UK will provide around 50% of the average annual household hot water requirements. Although the system may provide most of the hot water required in summer, the winter results, due to the lower intensity of the sun and the shorter daylight hours, will be reduced. As such the householder will need a boiler (or suitable alternative) to make up the difference in domestic hot water requirement and for the central heating of the house.

Q. Do I need to have a particular type of roof for Solar installation?

A. In the UK the best orientation for solar panels is facing due south and tilted at around 35 degrees from the horizontal. The gains available will reduce as the orientation moves away from due south. A variety of brackets and frames are available for solar systems to suit different roof types (pitched and flat) and different types of roof tiles.

Greenskies FK240 Solar Package

Worcester Greenskies FK240 solar package contents:

1. FK240 solar panels
2. AGS2 solar pump station
3. TDS10 solar controller
4. Automatic air vent
5. Expansion vessel
6. Heat transfer fluid (glycol)
7. Variety of roof fixings



Greenskies FK240 Solar Panel and accessories

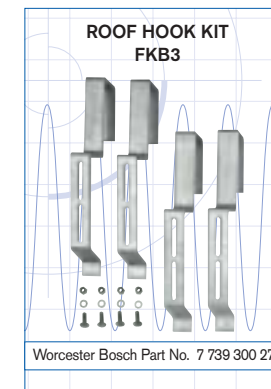
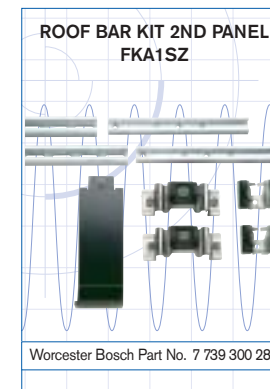
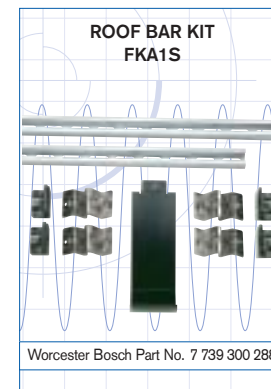
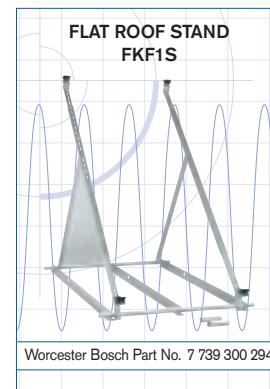
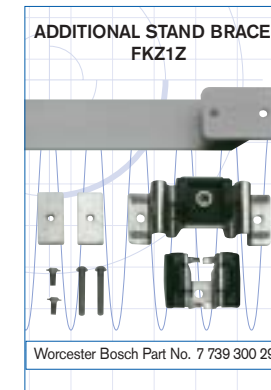
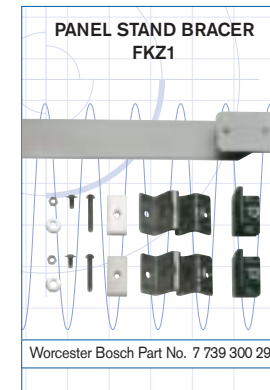
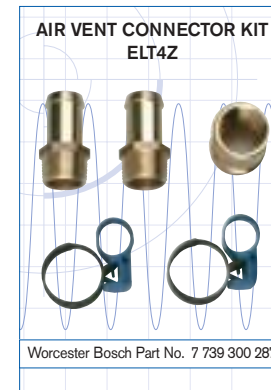
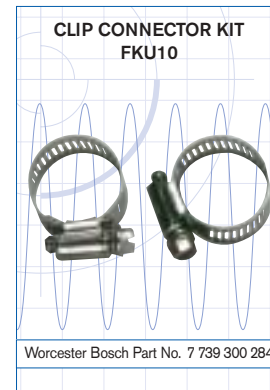
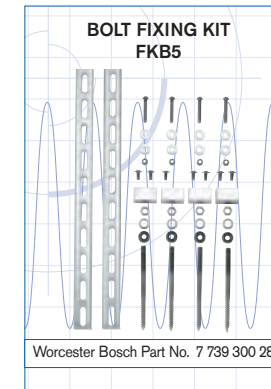
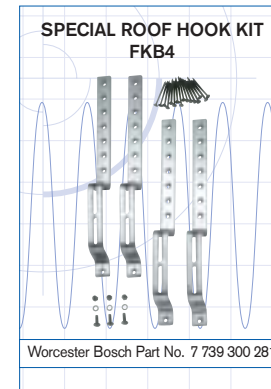
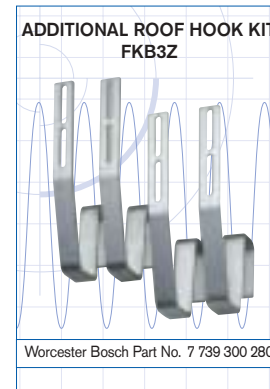
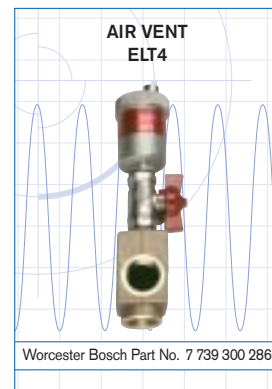
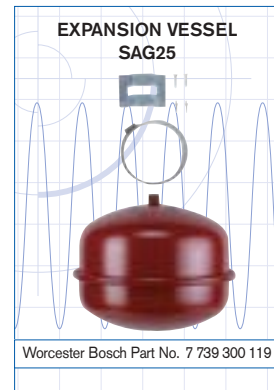
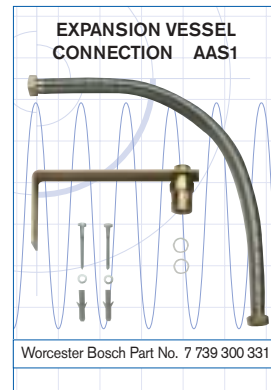
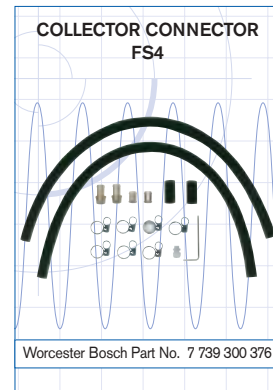
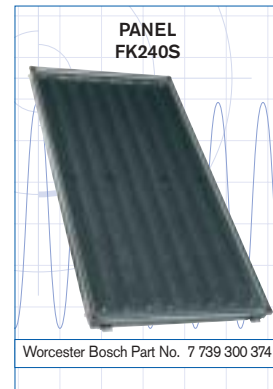

All the technical advice you need

The Worcester Bosch Technical Helpline is a dedicated phone line – dedicated to providing the best service from any manufacturer in the industry. Our team of technical experts provide the answers to queries of a technical nature on any product in the Worcester solar range, from application to installation to performance.

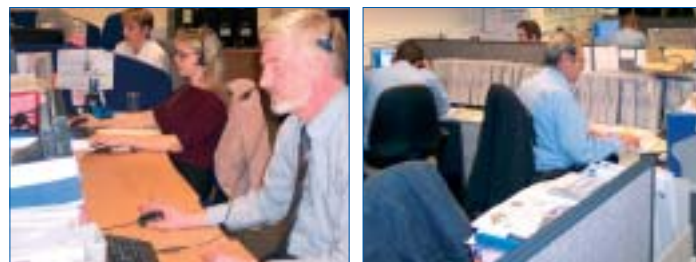

Pre-sales technical team.

Post-sales technical team.

The very best training programmes from Worcester Bosch

Worcester Bosch has always placed great emphasis on support and training for installers and service engineers. Today this need is greater than ever: one in every two boilers now purchased in the UK is a combi boiler and, month by month, an increasing number of condensing boilers are being installed. The differences between a combi, conventional and condensing boiler are substantial, and the technology of each continues to advance at a rapid pace.

To ensure the highest levels of competence and expertise in the installation of all Worcester Bosch boilers and Greenskies Solar Panels, the company runs intensive training courses for installers, commissioning engineers and engineers involved with servicing and fault finding.

Courses available



The Worcester Bosch Training Department has on offer a number of courses suitable for the installer and commissioning engineers, and a more in-depth course for the servicing and fault finding engineers.

State-of-the-art Worcester Bosch Training Academy

A recent addition to the excellent training facilities at the company's Worcester headquarters, this unique and advanced academy is the only one in the UK dedicated entirely to successful installation and commissioning of gas-fired and oil-fired boilers. The set-up is unique too:

4 custom-built workshops including one for solar, guide you step by step through a first-class troubleshooting course.

Regional Worcester Bosch Training Centres

The Worcester Bosch network of regional training centres is strategically located across the country to help put you within convenient travelling distance of the courses you wish to attend.

In addition to the outstanding facilities at the company's headquarters near Worcester, there are centres at Clay Cross in Derbyshire, Rochester in Kent, Blantyre in Scotland and Bangor, Northern Ireland. There are also additional training opportunities

available throughout the UK. Please phone 01905 752526 for more information about a course near you. Each course is run by specialist trainers and is superbly equipped to deliver a combination of classroom theory and practical hands-on experience that's second to none.

New Product Advance Training

Exclusive to Business Initiative members, these invaluable courses give you an introduction and insight into new Worcester Bosch products as soon as they are released on to the market.

College Links

A number of the country's leading proactive technical colleges are now equipped with Worcester Bosch products and offer excellent practical tuition on a more local level.

Distance Learning

A joint initiative from key names in the heating and plumbing industry, this offers a choice of low-cost home study elements compiled by experts. As a Business Initiative member you will receive a free Distance Learning CD which is packed with information.

Get on course for a more profitable future now

Call now for more information

01905 752526



Worcester Bosch Training Courses

Greenstar CDi, Highflow 440 and HE Plus gas-fired condensing combi boilers

Models covered Greenstar 25/30/35/40CDi
Greenstar Highflow 440
Greenstar 30/35/40 HE Plus

Duration 1 day

Greenstar i junior and Si gas-fired condensing combi boilers

Models covered Greenstar 24/28i Junior
Greenstar 25/30Si

Duration 1 day

Greenstar system and regular gas-fired condensing boilers

Models covered Greenstar 12/24Ri
Greenstar 30/40CDi Conventional
Greenstar 12/24i System

Duration 1 day

i Junior and Si II gas-fired combi boilers

Models covered 24i Junior
28i Junior
24Si II
28Si II

Duration 1 day

Danesmoor, Heatslave and Greenstar HE oil-fired boilers

Models covered Danesmoor
Heatslave
Greenstar

Duration 1 day

OFTEC Training

OFTEC 101

Covering Domestic/Light Commercial Pressure Jet Commissioning and Servicing

Duration 3 day course (2 days training plus 1 days assessment)

OFTEC 105e

Covering Domestic/Light Commercial Pressure Jet Boiler installation

Duration 1 day assessment

OFTEC 101 & 105e

Covering Domestic/Light Commercial Pressure Jet Installation, Commissioning and Servicing

Duration 3 day course (2 days training plus 1 days assessment comprising 2 theory and 1 practical)

OFTEC 600a

Covering Oil Tank Installation and Associated Controls

Duration 1 day assessment course

Certificate in Energy Efficiency for Domestic Heating Course

Covering Key elements of energy-efficient heating and hot water systems and products, compliance with the latest Building Regulations, how condensing boilers work and how they differ to non condensing products.

Duration 1 day

New 'A' Rated Academy

Covering Installation and Commissioning
Flues and Air Supply
Gas and Oil Supply
System Design and Flushing
Electrical Wiring and Control

Duration 2 days

Greenskies FK240 Solar Panels

Covering Installation, Commissioning and Marketing

Duration 1 1/2 days



Useful numbers

Sales

Tel: 01905 752640
Fax: 01905 456445
01905 455394

Technical (Pre & Post Sales)

Tel: 08705 266241
Fax: 01905 752741

Spares

Tel: 01905 752571
Fax: 01905 754620

Service

Tel: 08457 256206
Fax: 01905 757536
Livingston (Scotland)
Fax: 01506 441687

Training

Tel: 01905 752526
Fax: 01905 752535

Literature Line

Tel: 01905 752556

Your specialist Worcester Bosch
Greenskies Installer



Energy Efficiency is an Energy Saving Trust initiative backed by the Government.



www.worcester-bosch.co.uk

Worcester, Bosch Group,
Cotswold Way, Warndon, Worcester, WR4 9SW
Tel: 01905 754624 Fax: 01905 754619



Heating and Hot Water Comfort

Worcester Greenskies FK240 Solar Panels

Technical and Specification Information

